



BMW GS 1200 UPPER CRASHBARS

Part no: SBL.07.552.100

Please note that the upper crash bars must be fitted in conjunction with the SW-Motech bottom crash bars, part no SBL.07.312.100. Shown with optional projector spotlight kit

Erweiterung für Schutzbügel BMW R 1200 GS Extension for Crash Bar BMW R 1200 GS

Montagehinweise

Alle vom Motorrad gelösten Schrauben sind gemäß Herstellerangaben wieder zu montieren, oder mit von SW-MOTECH gelieferten Schrauben zu ersetzen. Falls nicht anderweitig definiert, diese Schrauben nach Tabelle anziehen.

M6	4,5 Nm
M8	8,0 Nm

Gegebenenfalls Schrauben mit flüssiger Schraubensicherung einkleben.

Prüfen Sie nach 50 km alle Verbindungen auf festen Sitz.

SW-MOTECH GmbH & Co. KG
Bahnhofstrasse 44d
35282 Rauschenberg
-Germany-

Tel.: ++ 49 (0) 6425 816 800
Fax: ++ 49 (0) 6425 816 810

www.sw-motech.com

Mounting Instructions

SW-MOTECH products should be installed by a qualified, experienced motorcycle technician. If you are unsure of your ability to properly install a product, please have the product installed by your local motorcycle dealer. SW-MOTECH takes no responsibility for damages caused by improper installation.

All screws, bolts, and nuts, including all replacement hardware provided by SW-MOTECH, should be tightened to the torque specified in the OEM maintenance manual for your motorcycle. If no torque specifications are provided in the OEM maintenance manual, the following torques may be used:

M6	4,5 Nm
M8	8,0 Nm

All screws, bolts, and nuts should be checked after driving the first 50 km to ensure that all are tightened to the proper torque.

Medium strength liquid thread-locker (i.e., "Locktite") should be used to secure all screws, bolts, and nuts.

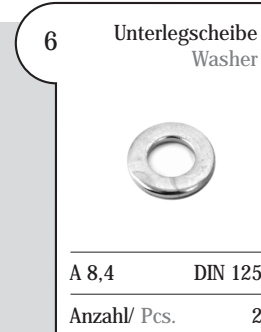
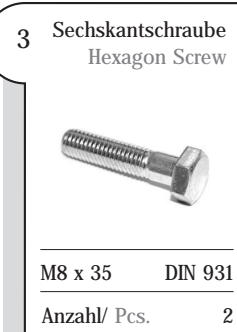
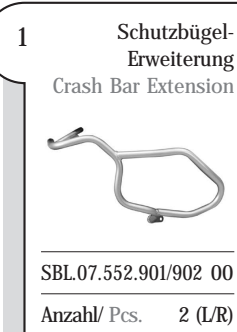

! Achtung: montierbar nur in Verbindung mit dem SW-MOTECH Schutzbügel (SBL.07.312.100).

Attention: attachable only with SW-MOTECH crash bar (SBL.07.312.100)

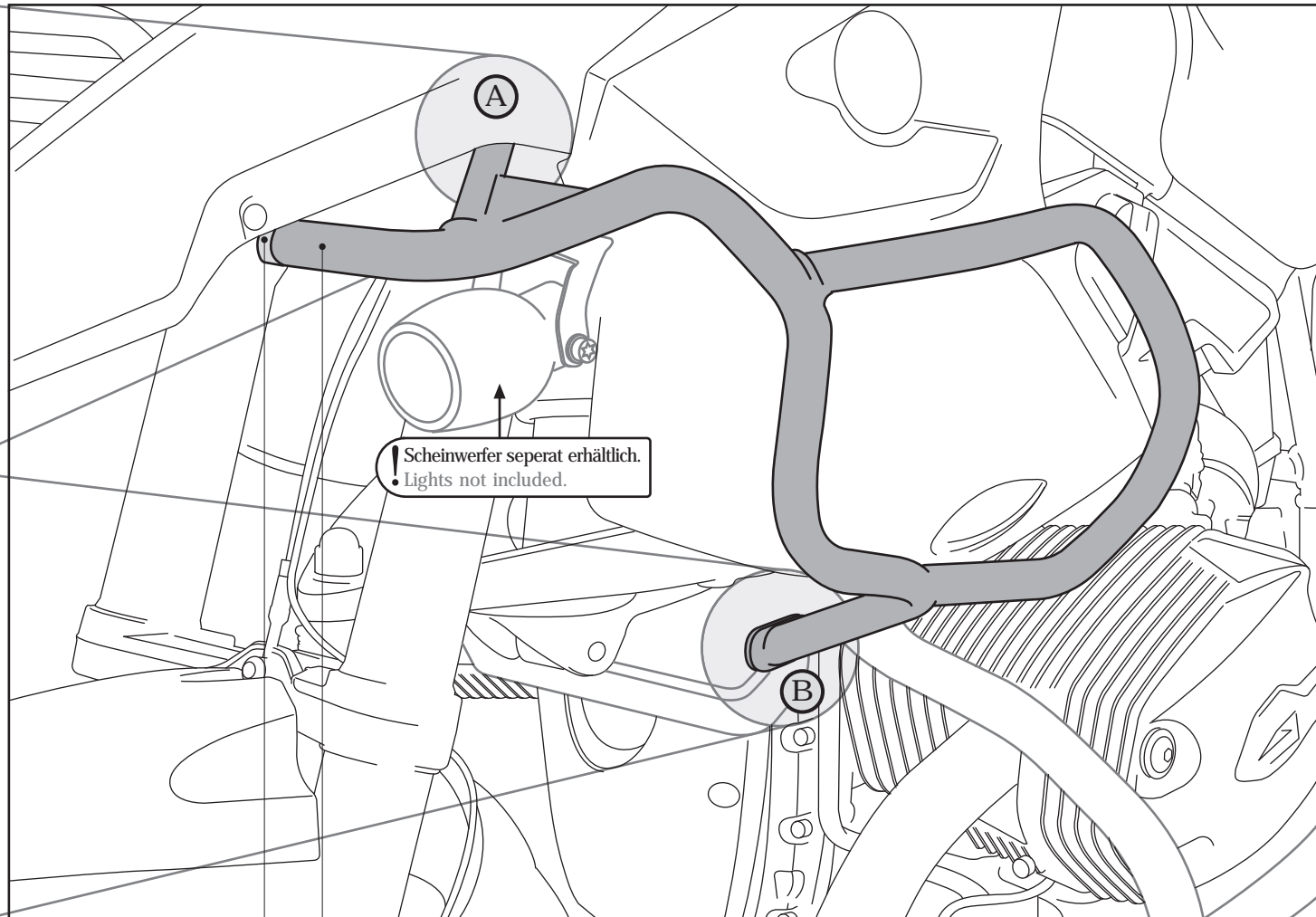
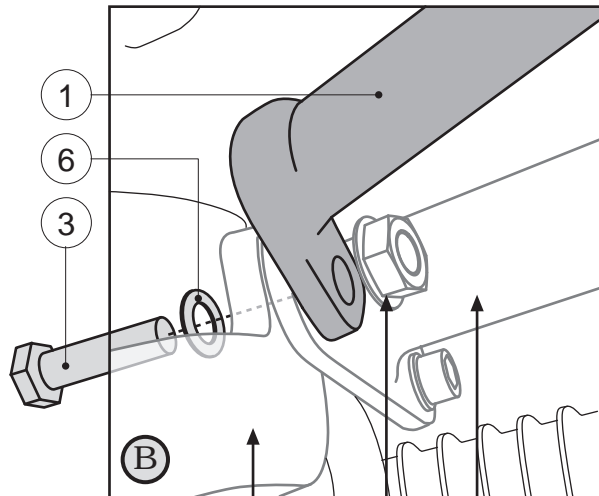
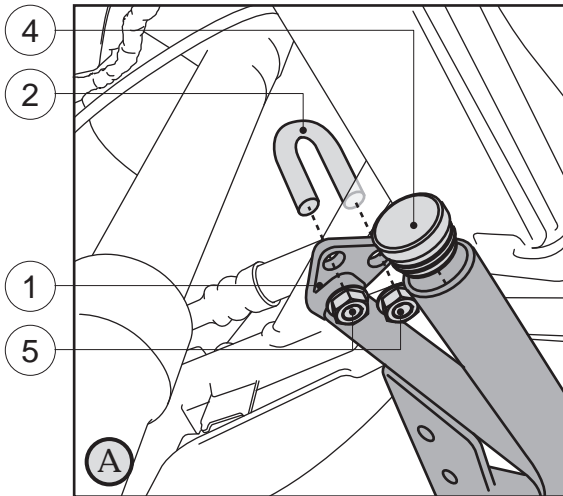

! Scheinwerfer seperat erhältlich.
! Lights not included.

! Achtung: Gezeigte Teile des SW-MOTECH
Schutzbügels (SBL.07.312.100) benutzen.
Attention: Use the shown parts of the
SW-MOTECH crash bar (SBL.07.312.100)
for installation.

