





YAMAHA FZ 1 Bj. '06

Schutzbügel Montagehinweise

Alle vom Motorrad gelösten Schrauben sind gemäß Herstellerangaben wieder zu montieren, oder mit von SW-MOTECH gelieferten Schrauben zu ersetzen. Falls nicht anderweitig definiert, diese Schrauben nach Tabelle anziehen.

M6	9,6 Nm
M8	23 Nm
M10	46 Nm

Gegebenenfalls Schrauben mit flüssiger Schraubensicherung einkleben.

Prüfen Sie nach 50 km alle Verbindungen auf festen Sitz.

Crash Bar Mounting Instructions

SW-MOTECH products should be installed by a qualified, experienced motorcycle technician. If you are unsure of your ability to properly install a product, please have the product installed by your local motorcycle dealer. SW-MOTECH takes no responsibility for damages caused by improper installation.

All screws, bolts and nuts, including all replacement hardware provided by SW-MOTECH, should be tightened to the torque specified in the OEM maintenance manual for your motorcycle. If no torque specifications are provided in the OEM maintenance manual, the following torques may be used:

M6	9,6 Nm
M8	23 Nm
M10	46 Nm

All screws, bolts and nuts should be checked after driving the first 50 km to ensure that all are tightened to the proper torque.

Medium strength liquid thread-locker (i.e., "Locktite") should be used to secure all screws, bolts and nuts.

SW-MOTECH GmbH & Co. KG
Bahnhofstrasse 44d
35282 Rauschenberg
-Germany-

Tel.: ++ 49 (0) 6425 816 800
Fax: ++ 49 (0) 6425 816 810

www.sw-motech.com

1 **Schutzbügel**
Crash Bar

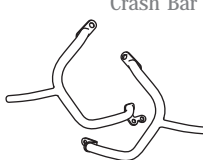

SBL.06.542.901/902 00
Anzahl/ Pcs. 2 (L/R)

2 **Innensechskantschraube**
Hexagon Socket Screw

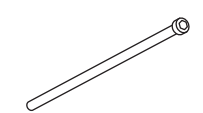

M10 x 280 DIN 912
Anzahl/ Pcs. 1

3 **Distanzbuchse**
Spacer

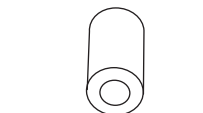

Da:20 Di:10,5 h:42
Anzahl/ Pcs. 1

4 **Mutter mit Bund, selbstsichernd**
Flanged Lock Nut



M10 DIN 6927
Anzahl/ Pcs. 1

5 **Innensechskantschraube**
Hexagon Socket Screw

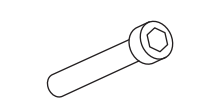

schwarz/black
M10x1,25x40 DIN 912
Anzahl/ Pcs. 2

6 **Unterlegscheibe**
Washer



A: 10,5 DIN 125
Anzahl/ Pcs. 5

7 **Innensechskantschraube**
Hexagon Socket Screw



M10x1,25x70 DIN 912
Anzahl/ Pcs. 2

8 **Distanzbuchse**
Spacer

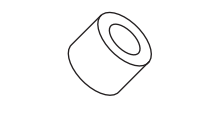

Da:20 Di:10,5 h:18
Anzahl/ Pcs. 2

9 **Klemmschelle**
Clamp

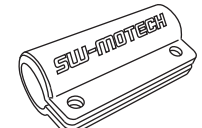

schwarz/black
SBL.00.051.002 01
Anzahl/ Pcs. 1

10 **Innensechskantschraube**
Hexagon Socket Screw

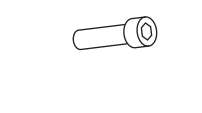

M6 x 20 DIN 912
Anzahl/ Pcs. 2

11 **Mutter, selbstsichernd**
Lock Nut

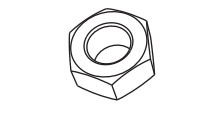

M6 DIN 985
Anzahl/ Pcs. 2

Linke Seite / left side

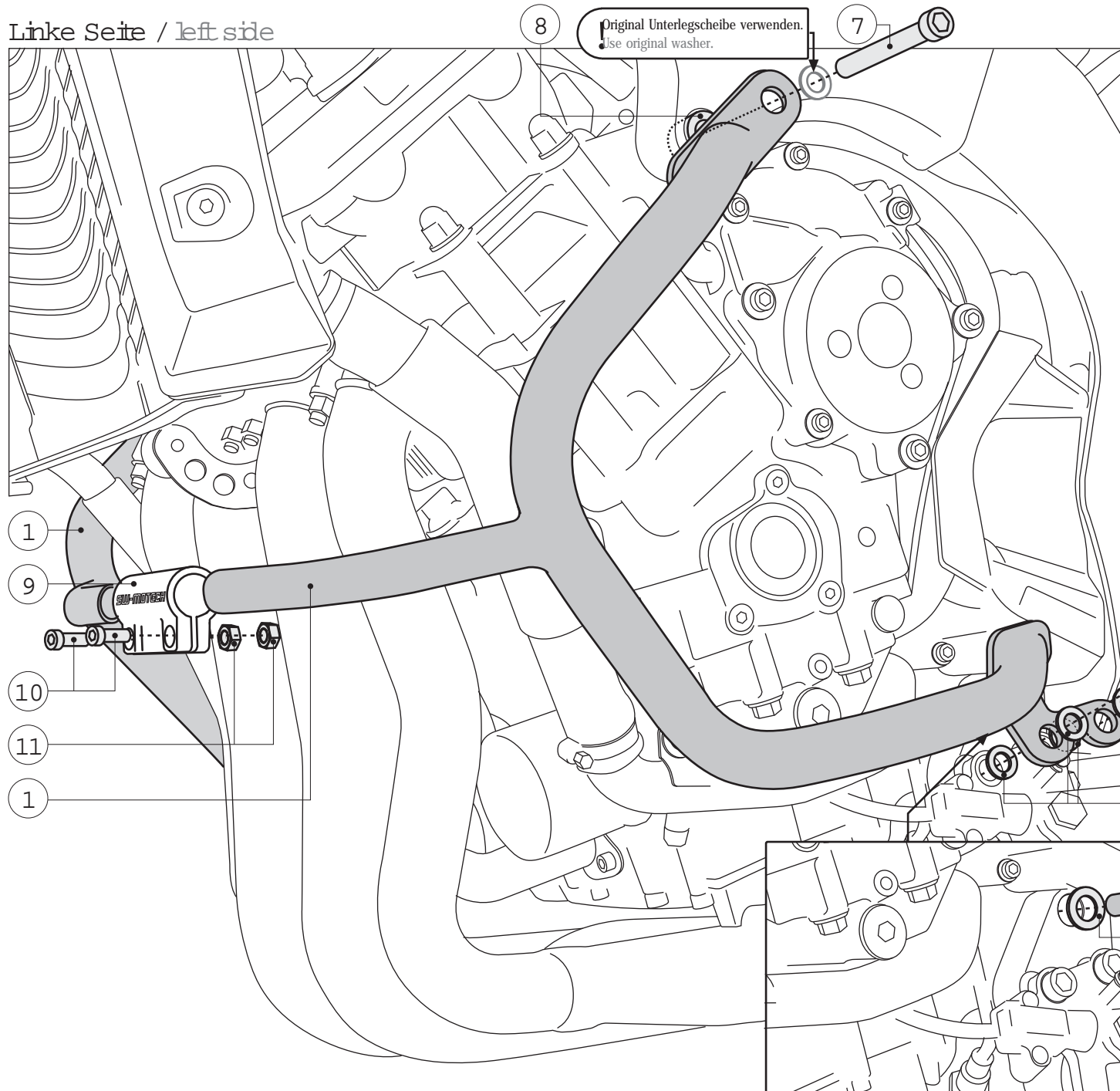

Original Unterlegscheibe verwenden.
Use original washer.

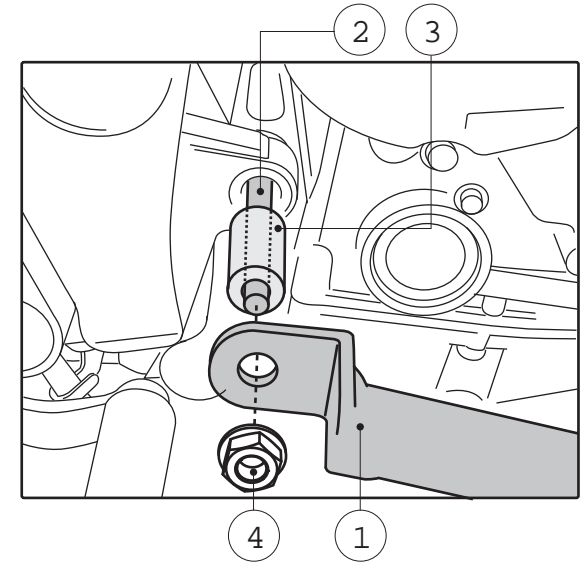

Rechte Seite / right side

! Die unteren beiden Unterlegscheiben (6) zum ausgleichen der Vertiefungen am original Seitenständer benutzen.
Use the both lower washers (6) to clear the space between the crash bar (1) and the original sidestand.

