

GPT.07.337.100



## BMW 1100 GS/1150 GS

### Alu-Rack Montagehinweise

Alle vom Motorrad gelösten Schrauben sind gemäß Herstellerangaben wieder zu montieren, oder mit von SW-MOTECH gelieferten Schrauben zu ersetzen. Falls nicht anderweitig definiert, diese Schrauben nach Tabelle anziehen.

M6	9,6 Nm
M8	23 Nm
M10	46 Nm

Gegebenenfalls Schrauben mit flüssiger Schraubensicherung einkleben.

Prüfen Sie nach 50 km alle Verbindungen auf festen Sitz.

Max. Zuladung 12 Kg.

Ist das Zuladungsgewicht des Fahrzeuges durch den Hersteller limitiert, gelten diese Grenzwerte.

SW-MOTECH GmbH & Co. KG  
Bahnhofstrasse 44d  
35282 Rauschenberg  
-Germany-

Tel.: ++ 49 (0) 6425 8168 00

Fax: ++ 49 (0) 6425 8168 10

www.sw-motech.com

### Alu-Rack Mounting Instructions

SW-MOTECH products should be installed by a qualified, experienced motorcycle technician. If you are unsure of your ability to properly install a product, please have the product installed by your local motorcycle dealer. SW-MOTECH takes no responsibility for damages caused by improper installation.









All screws, bolts and nuts, including all replacement hardware provided by SW-MOTECH, should be tightened to the torque specified in the OEM maintenance manual for your motorcycle. If no torque specifications are provided in the OEM maintenance manual, the following torques may be used:

M6	9,6 Nm
M8	23 Nm
M10	46 Nm

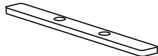
All screws, bolts and nuts should be checked after driving the first 50 km to ensure that all are tightened to the proper torque.

Medium strength liquid thread-locker (i.e., "Loctite") should be used to secure all screws, bolts, and nuts.

Max. Load On Rear Carrier: 12 Kg (26 lbs) or the motorcycle manufacturer's weight limit, whichever is less.

<p><b>1</b> Alu-Rack Alu-Rack</p>  <p>GPT.07.337.001 Anzahl/ Pcs. 1</p>	<p><b>5</b> Senkkopfschraube Countersunk Screw</p>  <p>M6 x 30 DIN 7991 Anzahl/ Pcs. 2</p>	<p><b>9</b> Schonstreifen Protection Stripe</p>  <p>Schonband Anzahl/ Pcs. 2</p>
<p><b>2</b> Abstandstraverse vorne Space Bracket</p>  <p>GPT.07.337.004 Anzahl/ Pcs. 1</p>	<p><b>6</b> Innensechskant- schraube Hexagon Socket Screw</p>  <p>M6 x 70 DIN 912 Anzahl/ Pcs. 2</p>	<p><b>6a</b> Innensechskant- schraube Hexagon Socket Screw</p>  <p>M6 x 90 DIN 912 Anzahl/ Pcs. 2</p>
<p><b>3</b> Abstandstraverse hinten Space Bracket</p>  <p>GPT.07.337.003 Anzahl/ Pcs. 1</p>	<p><b>7</b> Formhülse Molded Casing</p>  <p>HPA.00.038.005 Anzahl/ Pcs. 2</p>	<p>Nur benutzen, wenn Beifahrerhaltegriff montiert ist.  Use only, if the original handle is mounted.</p>
<p><b>4</b> Schraubtraverse hinten Fixing Bracket</p>  <p>GPT.07.337.002 Anzahl/ Pcs. 2</p>	<p><b>8</b> Mutter mit Bund Lock Nut</p>  <p>M6 DIN 6927 Anzahl/ Pcs. 2</p>	

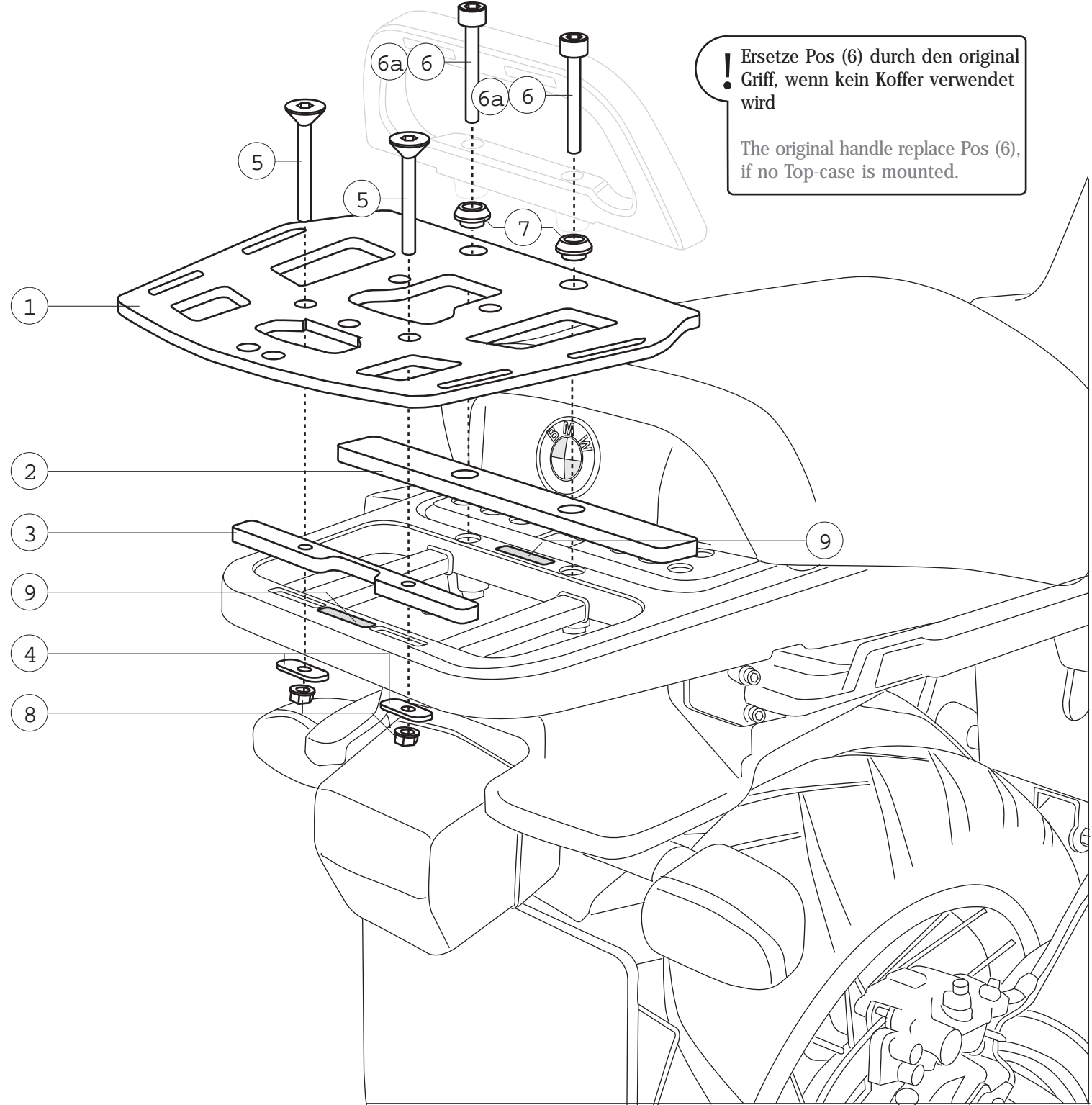

! Ersetze Pos (6) durch den original Griff, wenn kein Koffer verwendet wird

The original handle replace Pos (6), if no Top-case is mounted.

! Achtung: Falls die Montage einer Adapterplatte vorgesehen ist, MÜSSEN die Haltenocken am Alu-Rack vor dessen Anbau am Motorrad verschraubt werden.

Attention: Cam-locks from adapter kit MUST be installed before attaching the alu-Rack to the bike.