

Hauptständer HONDA XL 700 V '08 –
Centre Stand HONDA XL 700 V '08 –

Montagehinweise

Alle vom Motorrad gelösten Schrauben sind gemäß Herstellerangaben wieder zu montieren, oder mit von SW-MOTECH gelieferten Schrauben zu ersetzen.

Prüfen Sie nach 50 km alle Verbindungen auf festen Sitz.

Die Kurvenfreiheit kann durch einen Hauptständer eingeschränkt werden.

! Achtung: Die Kurven- und Bodenfreiheit kann durch einen Hauptständer eingeschränkt werden.

Attention: Cornering and ground clearance can be reduce by using a centre stand.

SW-MOTECH GmbH & Co. KG
Bahnhofstrasse 44d
35282 Rauschenberg
-Germany-

Tel.: ++ 49 (0) 6425 816 800
Fax: ++ 49 (0) 6425 816 810

www.sw-motech.com

Mounting Instruction

Centerstand cornering clearance: SW-MOTECH centerstands are carefully designed and tested to eliminate reductions in cornering clearance and ground clearance under most driving conditions on an unmodified stock motorcycle, and are certified to be compliant with European ABE safety standards. Use of any centerstand may reduce cornering clearance or ground clearance under extreme driving situations.

SW-MOTECH products should be installed by a qualified, experienced motorcycle technician. If you are unsure of your ability to properly install a product, please have the product installed by your local motorcycle dealer. SW-MOTECH takes no responsibility for damages caused by improper installation.

All screws, bolts and nuts, including all replacement hardware provided by SW-MOTECH, should be tightened to the torque specified in the OEM maintenance manual for your motorcycle.

All screws, bolts and nuts should be checked after driving the first 50 km to ensure that all are tightened to the proper torque.

Medium strength liquid thread-locker (i.e., "Loctite") should be used to secure all screws, bolts and nuts.

1 Hauptständer
Centre Stand



HPS.01.463.900 00
Anzahl/ Pcs. 1

5 Zugfedersatz
Spring Set



ZFD.00.150.009/ST 01
Anzahl/ Pcs. 1

2 Steckachse
Axle



HPS.01.035.001 02
Anzahl/ Pcs. 1

6 Gummischlag
Rubber Element



MSS.00.003.016
Anzahl/ Pcs. 2

3 Unterlegscheibe
Washer



A 21 DIN 125
Anzahl/ Pcs. 1

4 Splint
Pin



3,2 x 40 DIN 94
Anzahl/ Pcs. 1

Linke Seite / left side

! Achtung: mit Schmierfett einsetzen!
! Attention: insert with grease!

Fahrtrichtung
Driving direction

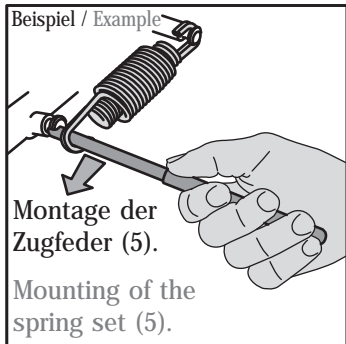
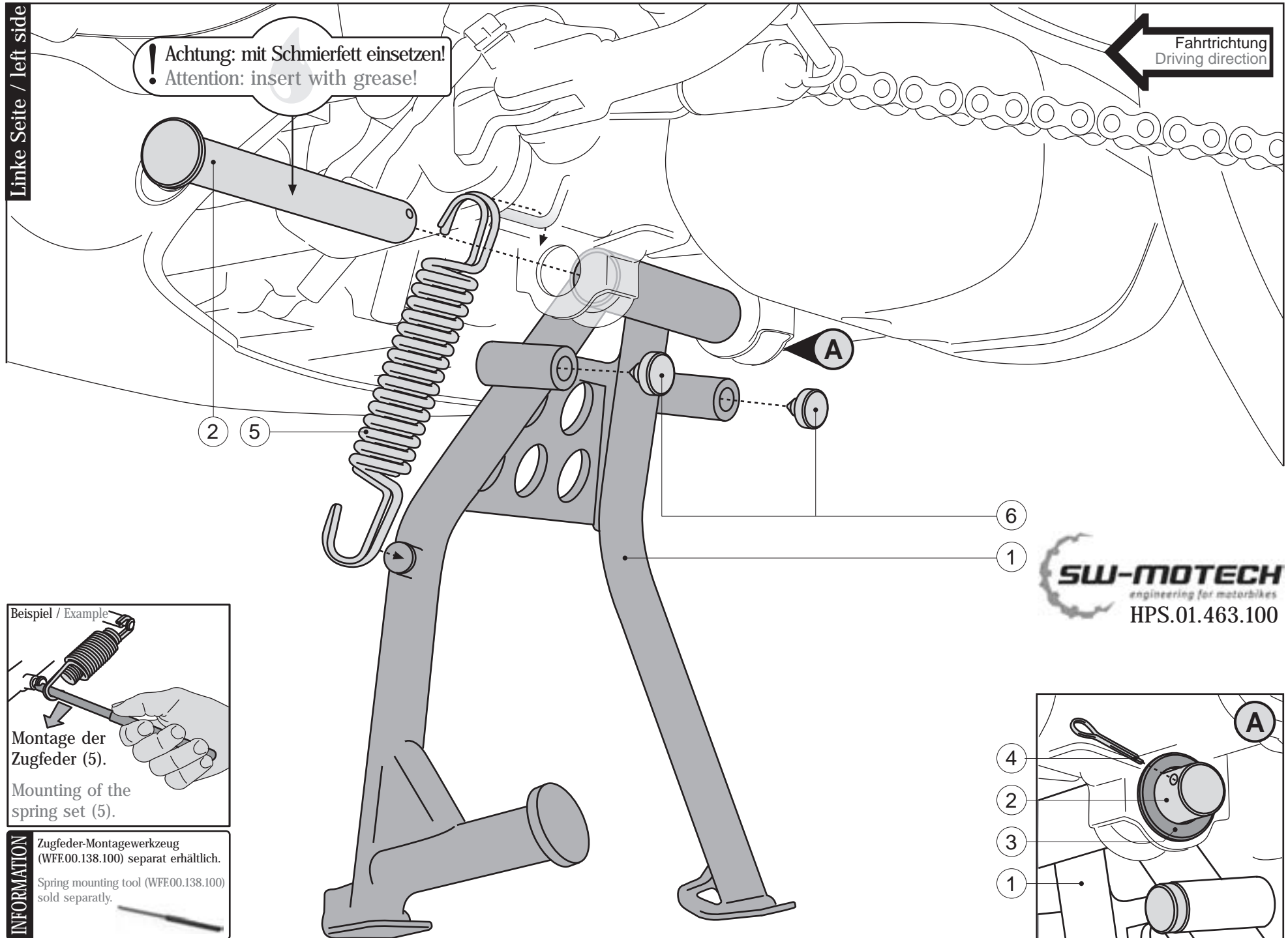

INFORMATION
Zugfeder-Montagewerkzeug (WFF00.138.100) separat erhältlich.
Spring mounting tool (WFF00.138.100) sold separately.

SW-MOTEC
engineering for motorbikes
HPS.01.463.100

