

QUICK-LOCK Seitenkofferträger

KTM LC4 ab Bj. 1999



Montagehinweise

Fahren Sie nicht ohne Koffer mit montierten Seitenplatten. Wenn sie ohne Gepäck fahren, Seitenplatten demontieren.

Alle vom Motorrad gelösten Schrauben sind gemäß Herstellerangaben wieder zu montieren, oder mit von SW-MOTECH gelieferten Schrauben zu ersetzen. Falls nicht anderweitig definiert, diese Schrauben nach Tabelle anziehen.

M6	9,6 Nm
M8	23 Nm
M10	46 Nm

Gegebenenfalls Schrauben mit flüssiger Schraubensicherung einkleben.

Prüfen Sie nach 50 km alle Verbindungen auf festen Sitz.

Maximale Zuladung der Koffer :
Gemäß Herstellerangaben

Mounting Instructions

German safety regulations require that no metal edge with a radius of less than 2.5mm be exposed while driving a motorcycle. Because Quick-Lock sidecase racks have edges with a radius of less than 2.5mm, Quick-Lock sidecase racks should not be used when luggage is not attached to them.

SW-MOTECH products should be installed by a qualified, experienced motorcycle technician. If you are unsure of your ability to properly install a product, please have the product installed by your local motorcycle dealer. SW Motech takes no responsibility for damages caused by improper installation.

All screws, bolts and nuts, including all replacement hardware provided by SW-MOTECH, should be tightened to the torque specified in the OEM maintenance manual for your motorcycle. If no torque specifications are provided in the OEM maintenance manual, the following torques may be used:

M6	9,6 Nm
M8	23 Nm
M10	46 Nm

All screws, bolts and nuts should be checked after driving the first 50 km to ensure that all are tightened to the proper torque.

Medium strength liquid thread-locker (i.e., "Loctite") should be used to secure all screws, bolts and nuts.

SW-MOTECH GmbH & Co. KG
Bahnhofstrasse 44d
35282 Rauschenberg
-Germany-

Tel.: ++ 49 (0) 6425 816 800
Fax: ++ 49 (0) 6425 816 810

www.sw-motech.com

Anziehen der Schrauben erst nach Befestigen und Justieren des Trägers

Fix screws after the side racks are fitted and adjusted

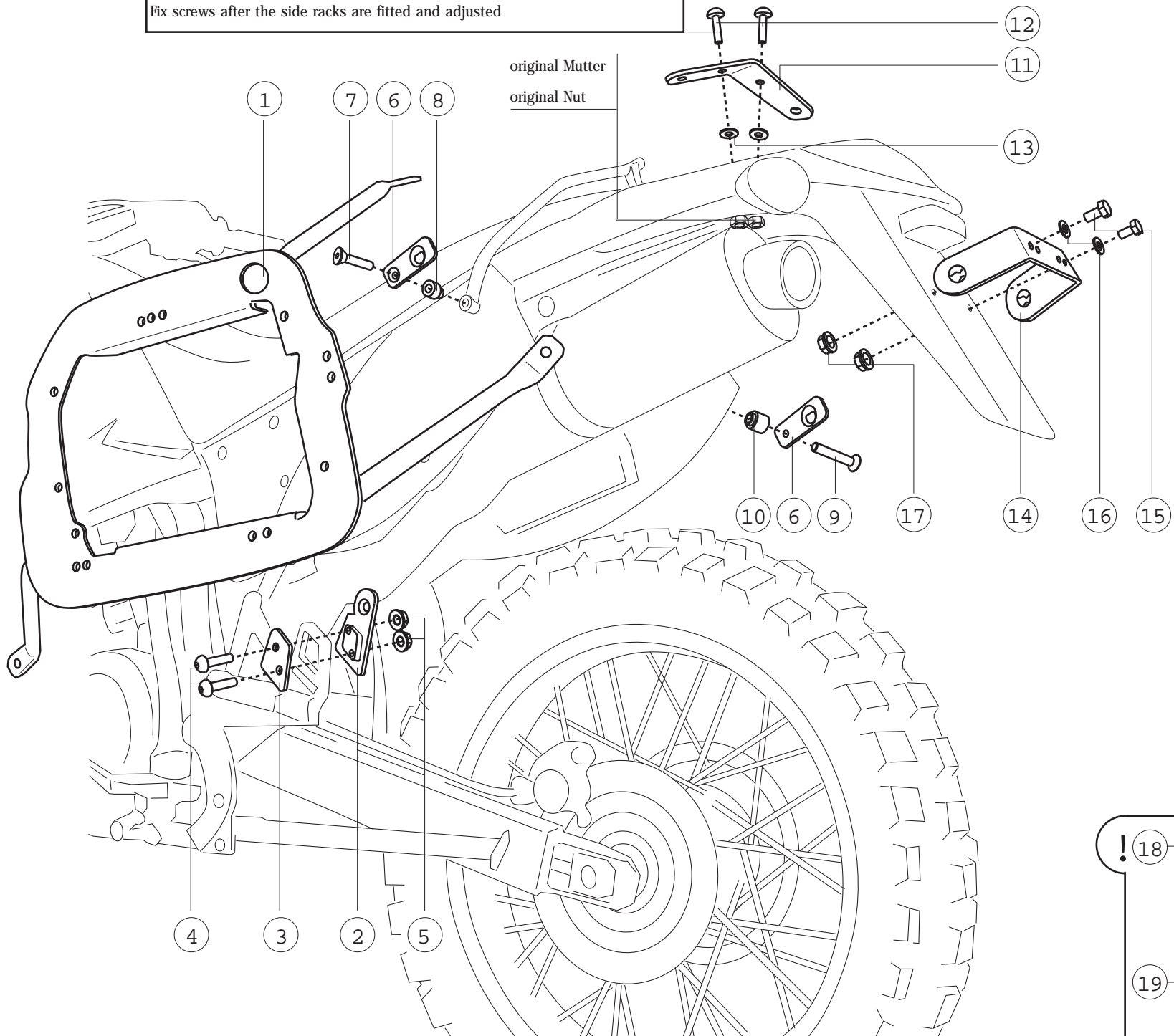

! Achtung: bei Verwendung der original Gepäckbrücke ggf. deren Durchgangsbohrung auf 9 mm aufbohren.

Attention: if you use the original top case carrier, it could be necessary to enlarge the through-hole to 9mm.

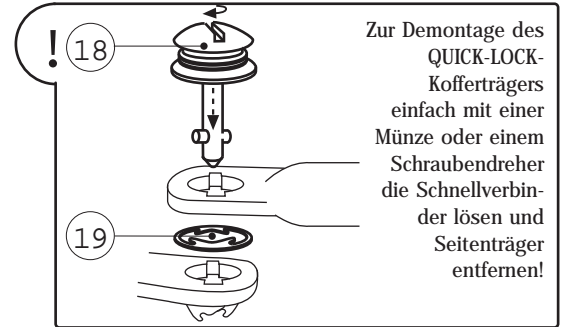

Zur Demontage des QUICK-LOCK-Kofferträgers einfach mit einer Münze oder einem Schraubendreher die Schnellverbinder lösen und Seitenträger entfernen!

1

Kofferträger
Side Bracket

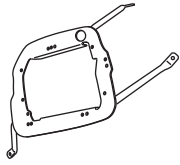

KFT.04.157.901/902

Anzahl/Pcs. 2 (L/R)

2

Befestigungsblech
Fußraste
Footrest Fixing Lug

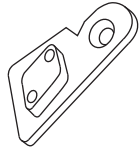

KFT.04.157.904/23

Anzahl/Pcs. (L/R) 2

6

Befestigungsblech
Haltegriff vorne
Handle Fixing Lug

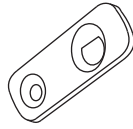

KFT.04.157.002

Anzahl/Pcs. 2

11

Querverbinder
Top Bracket

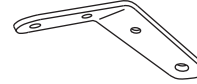

KFT.04.157.001

Anzahl/Pcs. 1

14

Querverbinder
Rear Bracket

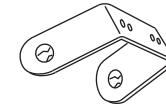

KFT.00.062.003

Anzahl/Pcs. 1

18

Schnellverschluss
Quick Fastener

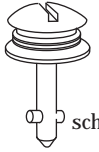

schwarz/
black

CAM.2312S21-12AHNV

Anzahl/Pcs. 8

3

Befestigungsblech
Cover Plate

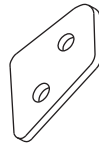

KFT.04.157.004/1

Anzahl/Pcs. 2

7

Senkkopfschraube
Countersunk screw

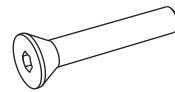

M6 x 70 DIN 7991

Anzahl/Pcs. 1

9

Senkkopfschraube
Countersunk screw

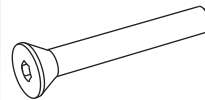

M6 x 60 DIN 7991

Anzahl/Pcs. 1

12

Linsenschraube
Lenshead Screw

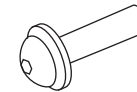

schwarz/black

M6 x 25 ISO 7380

Anzahl/Pcs. 2

15

Sechskantschraube
Hexagon Screw

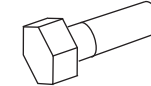

M6 x 20 DIN 933

Anzahl/Pcs. 2

19

Sicherungsring
Retaining ring



CAM.23.125.10-1BP

Anzahl/Pcs. 8

4

Linsenschraube
Lenshead

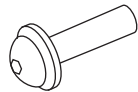

M6 x 25 ISO 7380

Anzahl/Pcs. 4

8

Distanzbuchse
Spacer



KFT.04.157.005/1

Anzahl/Pcs. 1

10

Distanzbuchse
Spacer



KFT.04.157.005/2

Anzahl/Pcs. 1

13

Gummischeibe
Rubber Washer



GS.00.06.025.003

Anzahl/Pcs. 2

16

Unterlegscheibe
Washer



A 6,4 DIN 125

Anzahl/Pcs. 2

5

Mutter mit Bund
Lock Nut



M 6 DIN 6927/b

Anzahl/Pcs. 4

17

Mutter mit Bund
Lock Nut



M 6 DIN 6927/b

Anzahl/Pcs. 2