



KFT.07.093.200
Revision: 00

QUICK-LOCK EVO-Träger QUICK-LOCK EVO-Carrier

Montagehinweise

Fahren Sie nicht ohne Koffer mit montierten Seitenplatten. Wenn sie ohne Gepäck fahren, Seitenplatten demontieren.

Alle vom Motorrad gelösten Schrauben sind gemäß Herstellerangaben wieder zu montieren, oder mit von SW-MOTECH gelieferten Schrauben zu ersetzen. Falls nicht anderweitig definiert, diese Schrauben nach Tabelle anziehen.

M6	9,6 Nm
M8	23 Nm

Gegebenenfalls Schrauben mit flüssiger Schraubensicherung einkleben.

Prüfen Sie nach 50 km alle Verbindungen auf festen Sitz.

Max. Zuladung 5 Kg pro Koffer.

SW-MOTECH GmbH & Co. KG
Ernteweg 8/10
35282 Rauschenberg
Germany

Tel. +49 (0) 64 25/8 16 8-00
Fax +49 (0) 64 25/8 16 8-10

info@sw-motech.com
www.sw-motech.com

BMW R 1100 GS / R 1150 GS BMW R 1100 GS / R 1150 GS

Mounting Instructions

German safety regulations require that no metal edge with a radius of less than 2.5mm be exposed while driving a motorcycle. Because Quick-Lock sidecase racks have edges with a radius of less than 2.5mm, Quick-Lock sidecase racks should not be used when luggage is not attached to them.

SW-MOTECH products should be installed by a qualified, experienced motorcycle technician. If you are unsure of your ability to properly install a product, please have the product installed by your local motorcycle dealer. SW Motech takes no responsibility for damages caused by improper installation.

All screws, bolts and nuts, including all replacement hardware provided by SW-MOTECH, should be tightened to the torque specified in the OEM maintenance manual for your motorcycle. If no torque specifications are provided in the OEM maintenance manual, the following torques may be used:

M6	9,6 Nm
M8	23 Nm

All screws, bolts and nuts should be checked after driving the first 50 km to ensure that all are tightened to the proper torque.

Medium strength liquid thread-locker (i.e., "Loctite") should be used to secure all screws, bolts and nuts.

Max. Load 5 Kg (11 lbs) per case.

! USA ONLY: Installation requires removal or relocation of the carbon canister!

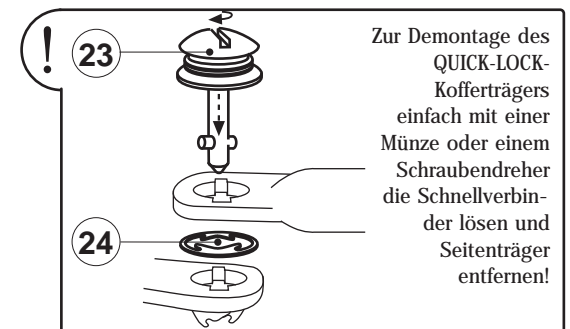
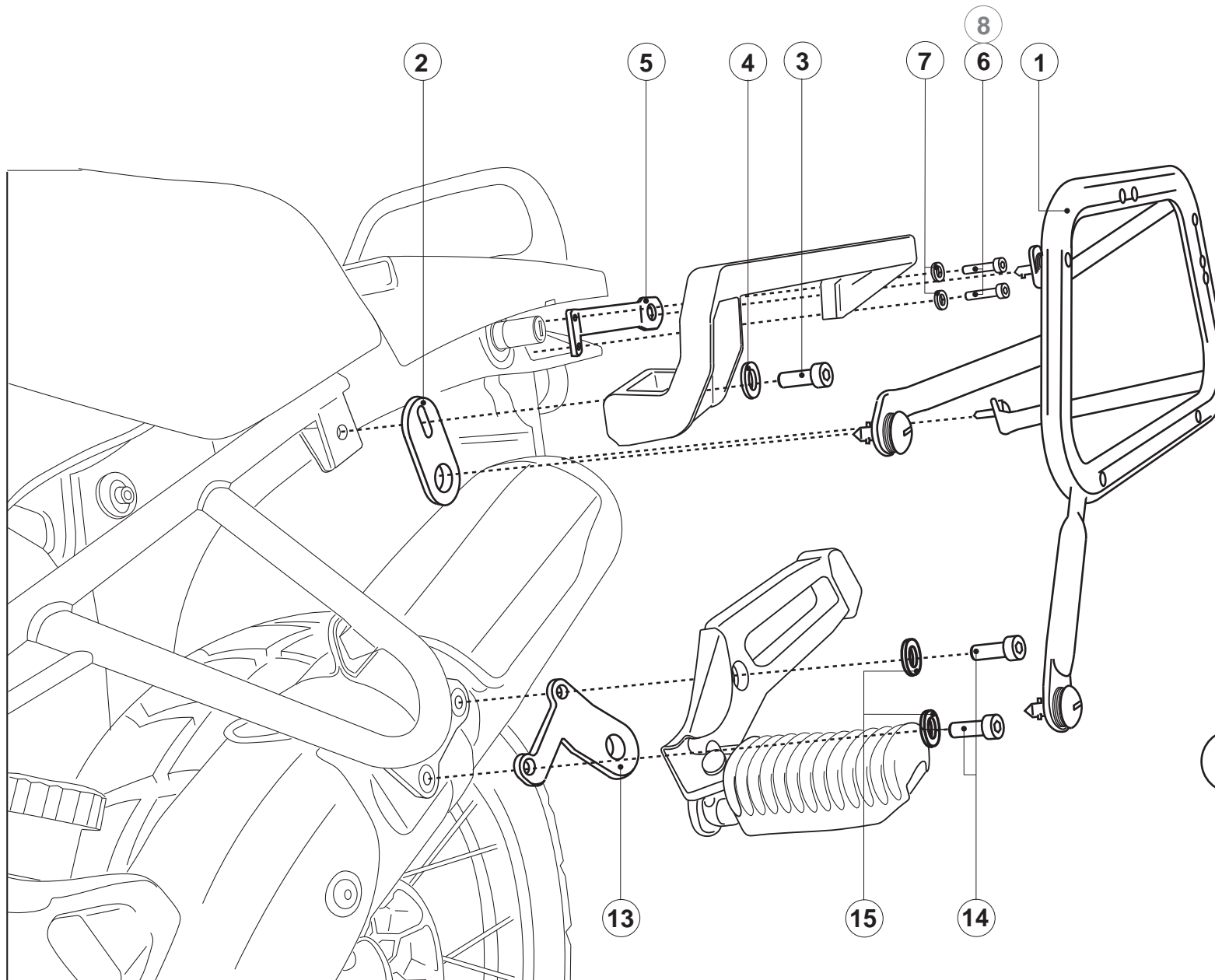

Zur Demontage des
 QUICK-LOCK-
 Kofferträgers
 einfach mit einer
 Münze oder einem
 Schraubendreher
 die Schnellverbin-
 der lösen und
 Seitenträger
 entfernen!

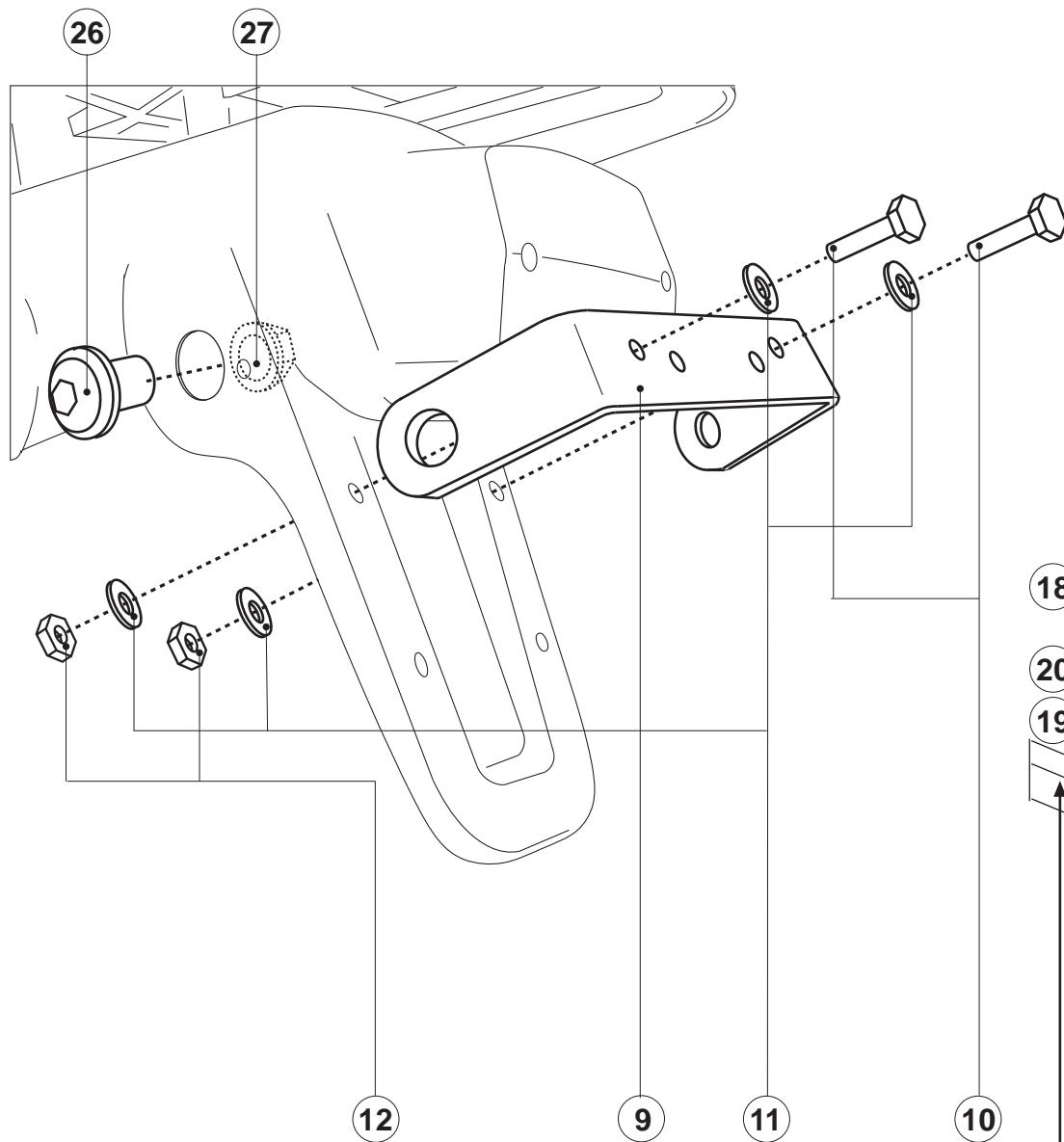

! Schraube (17a) nur benutzen, wenn SW-MOTECH Alu-Rack montiert ist.
 Use the screw (17a) only, if the SW-MOTECH alu rack is mounted.

! Die Blinker mit Hilfe der Kabelverlängerung (25) sowie den Steckverbindern (25a/25b) mit dem Bordnetz verbinden.
 Use the cable extension (25) and the connectors (25a/25b) to connect the blinker with the electrical system of the motorcycle.

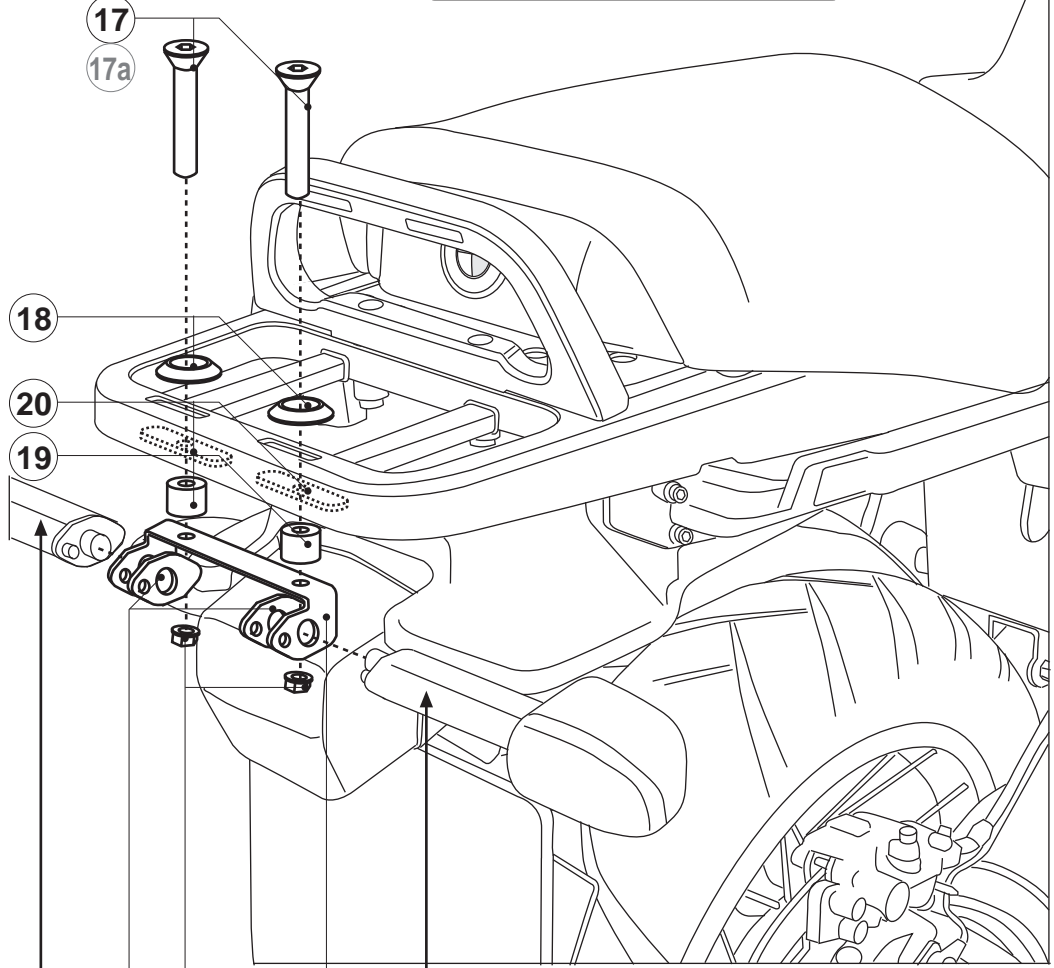

! Blinker mit original Mutter an der Traverse verschrauben.
 Use the original nut to mount the blinker on the bracket.

1

EVO-Träger
EVO-Carrier

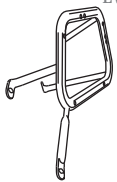

KFT.07.093.961/962

Anzahl/ Pcs. 2 (L/R)

2

Befestigungsblech
Fixing Lug



KFT.00.064.001/1 04

Anzahl/ Pcs. 2

5

Befestigungsblech
Fixing Lug

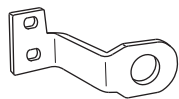

KFT.07.093.001 02

Anzahl/ Pcs. 2 (L/R)

9

Querverbinder
Cross Girder

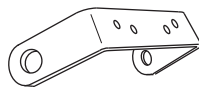

KFT.00.062.003 02

Anzahl/ Pcs. 1

13

Befestigungsblech
Fixing Lug

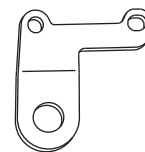

KFT.07.093.002 01

Anzahl/ Pcs. 2 (L/R)

16

Blinkerverlegung
Indicator Bracket

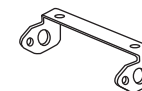

KFT.07.093.004/1 01

Anzahl/ Pcs. 1

20

Angleichplatte
Adapter Plate

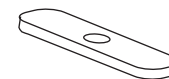

GPT.07.337.002 03

Anzahl/ Pcs. 2

3

Zylinderschraube
mit Innensechskant
Hexagon Socket Screw

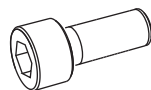

M8 x 30 DIN 912

Anzahl/ Pcs. 2

6

Zylinderschraube
mit Innensechskant
Hexagon Socket Screw

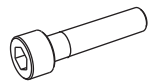

M6 x 20 DIN 912

Anzahl/ Pcs. 4

10

Sechskantschraube
Hexagon Screw

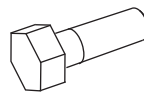

M6 x 20 DIN 933

Anzahl/ Pcs. 2

14

Zylinderschraube
mit Innensechskant
Hexagon Socket Screw

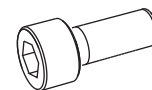

M8 x 20 DIN 6912

Anzahl/ Pcs. 4

17

Senkkopfschraube
Countersunk Screw

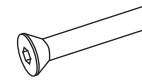

M6 x 45 DIN 7991

Anzahl/ Pcs. 2

21

Mutter mit Bund
Lock Nut



M6 DIN 6927/b

Anzahl/ Pcs. 2

4

Unterlegscheibe
Washer



A 8,4 DIN 125

Anzahl/ Pcs. 2

7

Unterlegscheibe
Washer



A 6,4 DIN 125

Anzahl/ Pcs. 4

11

Unterlegscheibe
Washer



A 6,4 DIN 9021

Anzahl/ Pcs. 4

15

Unterlegscheibe
Washer



A 8,4 DIN 125

Anzahl/ Pcs. 4

18

Senkscheiben
Sunk Washer



SE.00.064.01

Anzahl/ Pcs. 2

22

Abdeckblech
Cover



KFT.07.093.004/2 01

Anzahl/ Pcs. 2



Nur bei Verwendung
des original BMW
Koffertägers.

Just use with original
BMW luggage rack.

8

Zylinderschraube
mit Innensechskant
Hexagon Socket Screw

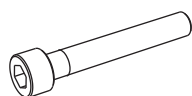

M6 x 40 DIN 912

Anzahl/ Pcs. 4

12

Mutter selbstsichernd
Lock Nut



M6 DIN 985

Anzahl



19

Distanzbuchse
Spacer



Da:14 Di:6,4 h:22

Anzahl/ Pcs. 2

17a

Senkkopfschraube
Countersunk Screw

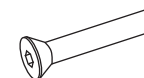

M6 x 60 DIN 7991

Anzahl/ Pcs. 2

23 Schnellverschluss mit
 Federscheibe
 Quick Fastener

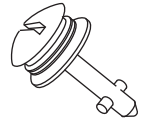

CAM.2312S21-12AHNV
 Anzahl/ Pcs. 8

24 Sicherungsring
 Retaining Ring



CAM.23.125.10-1BP
 Anzahl/ Pcs. 8

25 Kabelverlängerung
 Cable Extension



Kabelverlängerung 150 mm
 Anzahl/ Pcs. 2

25a Steckverbinderzunge
 blau
 Connector Male blue



STZ.00.048.FL
 Anzahl/ Pcs. 4

25b Steckverbinderhülse
 blau
 Connector Female blue



STH.00.048.FL
 Anzahl/ Pcs. 4

26 Linsenkopfschraube
 Lenshead Screw
 schwarz/black

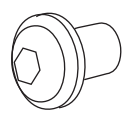

M10 x 16 ISO 7380
 Anzahl/ Pcs. 2

27 Mutter mit Bund
 Lock Nut

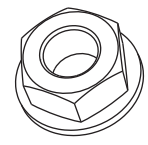

M10 DIN 6927
 Anzahl/ Pcs. 2