

MSS.05.296.100



## SUZUKI DL 650 V-Strom Motorschutz Montagehinweise

Alle vom Motorrad gelösten Schrauben sind gemäß Herstellerangaben wieder zu montieren, oder mit von SW-MOTECH gelieferten Schrauben zu ersetzen. Falls nicht anderweitig definiert, diese Schrauben nach Tabelle anziehen.

M6	9,6 Nm
M8	23 Nm
M10	46 Nm

Gegebenenfalls Schrauben mit flüssiger Schraubensicherung einkleben.

Prüfen Sie nach 50 km alle Verbindungen auf festen Sitz.

Maximale Zuladung der Koffer :  
Gemäß Herstellerangaben

SW-MOTECH GmbH & Co. KG  
Bahnhofstrasse 44d  
35282 Rauschenberg  
-Germany-

Tel.: ++ 49 (0) 6425 8168 00  
Fax: ++ 49 (0) 6425 8168 10

[www.sw-motech.com](http://www.sw-motech.com)

## Skid plate Mounting Instructions

SW-MOTECH products should be installed by a qualified, experienced motorcycle technician. If you are unsure of your ability to properly install a product, please have the product installed by your local motorcycle dealer. SW-MOTECH takes no responsibility for damages caused by improper installation.

All screws, bolts and nuts, including all replacement hardware provided by SW-MOTECH, should be tightened to the torque specified in the OEM maintenance manual for your motorcycle. If no torque specifications are provided in the OEM maintenance manual, the following torques may be used:

M6	9,6 Nm
M8	23 Nm
M10	46 Nm

All screws, bolts and nuts should be checked after driving the first 50 km to ensure that all are tightened to the proper torque.

Medium strength liquid thread-locker (i.e., "Loctite") should be used to secure all screws, bolts and nuts.

**! Achtung:**  
Dieser Motorschutz kann nur mit dem original Suzuki oder dem SW-MOTECH Schutzbügel montiert werden

**Attention:**  
The skid plate can only be mounted with the original Suzuki or the SW-MOTECH crash bar

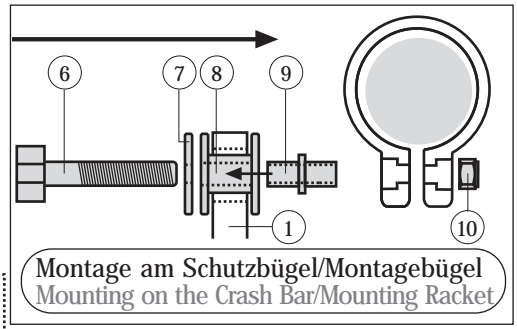
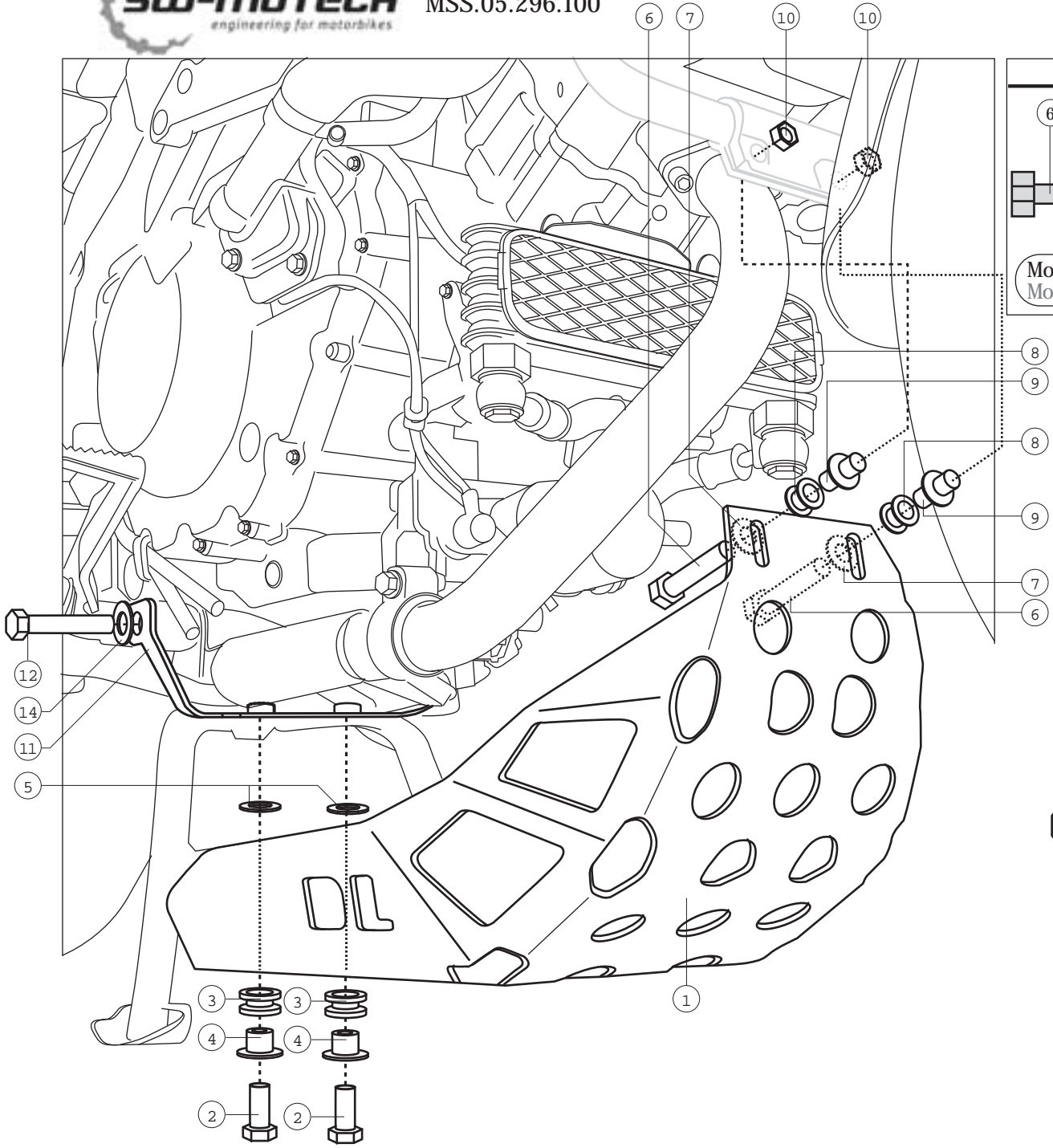

**!** Justage des Motorschutzes über die Langlöcher in Fahrtrichtung. Nur so kann ausreichender Abstand zwischen Motorschutz und Auspuff gewährleistet werden.

Adjust the skid plate with the ablons holes (in driving direction) to have enough space between the exhaust and skid plate.

**!** Achtung: Die Kurven- und Bodenfreiheit kann durch einen Motorschutz eingeschränkt werden.

Attention: Cornering and ground clearance can be reduced by using a skid plate.

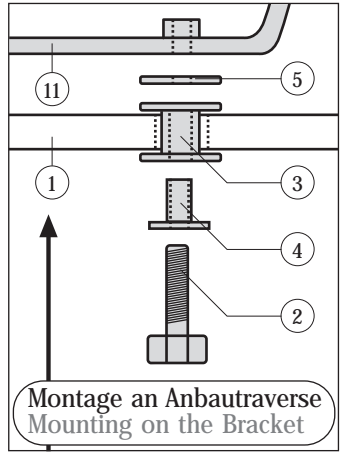
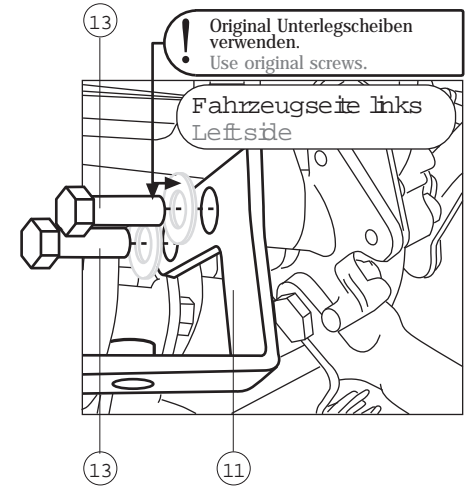

**1** Motorschutz  
Skid plate



MSS.05.296.900  
 Anzahl/ Pcs. 1

**2** Sechskantschraube  
Hexagon Screw

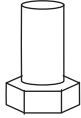

M8 x 20 DIN 933  
 Anzahl/ Pcs. 2

**6** Sechskantschraube  
Hexagon Screw

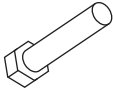

M6 x 40 DIN 931  
 Anzahl/ Pcs. 2

**10** Mutter, selbstsichernd  
Lock Nut



M6 DIN 985  
 Anzahl/ Pcs. 2

**11** Anbautraverse  
Bracket

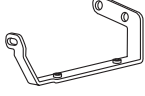

MSS.05.296.005  
 Anzahl/ Pcs. 1

**3** Gummitülle  
Rubberelement



GT.00.12H3488  
 Anzahl/ Pcs. 2

**7** Unterlegscheibe  
Washer



A 6,4 DIN 9021  
 Anzahl/ Pcs. 2

**12** Sechskantschraube  
Hexagon screw

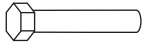

M8 x 50 DIN 931  
 Anzahl/ Pcs. 1

**14** Unterlegscheibe  
Washer



A 8,4 DIN 12  
 Anzahl/ Pcs. 1

**4** Distanzbuchsen mit  
Bund  
Spacer



MSS.05.296.006  
 Anzahl/ Pcs. 2

**8** Gummitülle  
Rubberelement



GT.00.12H3472  
 Anzahl/ Pcs. 2

**13** Sechskantschraube  
Hexagon Screw

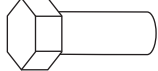

M12 x 1,25 x 35 DIN 960  
 Anzahl/ Pcs. 2

**5** Unterlegscheibe  
Washer



A 8,4 DIN 9021  
 Anzahl/ Pcs. 2

**9** Distanzbuchsen mit  
Bund  
Spacer

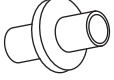

MSS.05.296.004  
 Anzahl/ Pcs. 2