

Small, reinforced passenger seat bag with the famous stable 4 point-fitting. Main bag is waterproof even without inner bags, because of its overlapping top cover. Side bags (one detaches to become a hip-pack) with waterproof zipper. Volume c. 25 lit., expandable to c. 38 lit. by circular zipper.



Includes:

- Expandable passenger-seat bag
- 4 mounting straps
- 2 backpack-straps,
- 2 support straps for licence plate installation
- scratch resistant film

Rearbag on GSXR K3, full volume (38 lit.)

full Volume (38 ltr.)



Rearbag tested on racetrack



Rearbag usable as backpack



Article	Notes	Part number
Rearbag		BCK.RB4021 129.00



RearBag features:

- ***Expandable passenger seat bag***
- ***2 side compartments one of which is detachable and can be used as a hip-pack***
- ***Shoulder straps for off bike use as a backpack***
- ***Integrated aluminum self supporting construction maintains the shape and requires no hard luggage rack***
- ***Racetrack tested***
- ***Hand-made from an industry leading 1200 denier high-tenacity ballistic nylon yarn which surpasses leather, Cordura and nylon in strength.***
- ***Waterproof, seam sealed inlays.***
- ***All internal material is also lined with a water-resistant PE polymer***
- ***Reflective webbing adds conspicuity at night.***
- ***Heavy-duty zippers offer oversized pulls for easier manipulation with gloves***
- ***25 to 38 liters of storage volume through expanding function***
- ***Solid hold four point fitting.***

Standard accessories: 4 fitting straps, 2 support straps for license plate mounting points, 2 backpack straps, paint protection film.

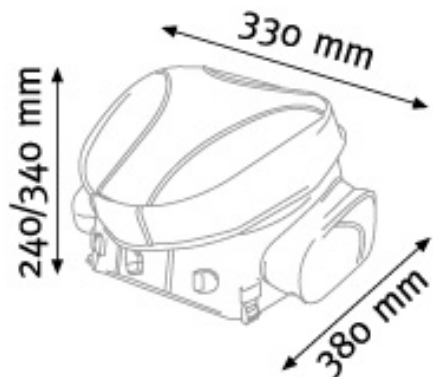

Bags-Connection has tested its products on most current-model motorcycles. Based on these fitting tests, Bags-Connection recommends the RearBag for use with the unmodified stock bikes listed below (product may also fit additional motorcycle models):

Aprilia

RSV1000R Mille, -2003

RSV1000R Mille & RSV1000R Factory, 2004-

SL1000 Falco

Tuono 1000R

ETV1000 Caponord

Buell

Firebolt XB9R

Firebolt XB12R

BMW

F650CS

F650GS/Dakar

K1200GT

K1200RS

K1200R

K1200S

R1100S

R1150GS

R1150GS Adventure

R1150R

R1150RS

R1150RT

R1200GS
R1200RT
R850R

Ducati

SS1000DS Supersport
ST3
ST4
Monster 620 / 1000
Monster S2R / S4R
916 / 996

Harley-Davidson

XL 883 Sportster 2004
XL 883C Sportster Customer 2004
FXD Dyna Super Glide 2004
FXDX Dyna Super Glide Sport 2004
FXDL Dyna Low Rider 2004
FXDWG Dyna Wide Glide 2004
Softail Standard FXST/FXSTI 2004
V-Rod 2004

Honda

CBF500 / CBF600
CB1300
599 / CB600 Hornet
919 / CB900 Hornet
CBR1000RR
VTR1000 SP1 / SP2
VTR1000F Superhawk
CBR600RR
CBR600F / CBR600F4i
CBR1100XX Blackbird
VFR750, -'97
VFR800 Interceptor, '98-'01
VFR800 VTEC Interceptor, '02-
ST1300 Pan-European
NT650 Deauville
Varadero XL1000V
Varadero XL125V
Transalp XL650V

Kawasaki

ZX6R (636cc)
ZX6RR (599cc)
ZX10R
ZX12R
Z750S
Z1000
ZRX1200
ZZR600

ZZR1200
KLE500
KLR650
VN800 Vulcan Classic
VN1600 Vulcan Classic
VN1600 Vulcan Mean Streak
VN2000 Vulcan
W650

KTM

LC4 Adventure 640
LC4 Enduro
LC8 Adventure 950 & 950/S
LC8 Adventure 990 & 990/S

Moto Guzzi

California EV
V11
V750 Brevia
Nevada 750 Classic IE

Suzuki

GSXR600
GSXR750
GSXR1000, -'04
GSXR1000, '05-
GSX1300R Hayabusa
SV650, '03-
SV1000, '03-
GSX600F Katana
GSX750F Katana
GSF600 & GSF600S Bandit, -'04
GSF650 & GSF650S Bandit, '05-
GSF1200 & GSF1200S Bandit
GSX1400
GS500E
GS500F
DL650 V-Strom
DL1000 V-Strom
DRZ400S & DRZ400SM

Triumph

Rocket III
Sprint ST 1050
Daytona 650
Daytona 955i
Tiger 955i
Speed Triple, 2004-
Speed Triple, -2003
Speed Four
Thruxton 900

Bonneville T100
Bonneville

Yamaha

MT01

YZF-R1

YZF-R6

FJR1300

FZ1 (FZS1000 Fazer)

FZ6

TDM900

XJR1300

BT1100 Bulldog

XVS650 V-Star / V-Star Classic

XVS1100 V-Star / V-Star Classic

XVZ1600 / XVZ1700 Road Star

