

Speedpack-Wide

This new Version of the Speedpack is constructed with a wider space between the sidebags to fit on bikes with a wider tail section, wide passenger hand-grips or underseat exhausts, like the R1, CBR 1000 RR, Aprilia RSV, F650GS, Fazer 1000...

The outer profile of the speedpack remains the same as the original.

self-supporting construction



Includes:

- Three-part luggage- and inlay set
- 4 mounting straps
- 2 compression belts
- shoulder strap
- 2 support straps for licence plate installation
- scratch resistant film

Mounted

proper clearance between exhaust and sidebags



Waterproof inlays



self-supporting construction



Article	Notes	Part number
Speedpack-wide		BCK.SP5001



Speedpack Wide features:

- ***Integrated aluminum self supporting construction maintains the shape and requires no hard luggage rack***
- ***Racetrack tested***
- ***Hand-made from an industry leading 1200 denier high-tenacity ballistic nylon yarn which surpasses leather, Cordura and nylon in strength.***
- ***Waterproof ,seam sealed separate inlays.***
- ***All internal material is also lined with a water-resistant PE polymer***
- ***Separate access to main and side compartments.***
- ***Purposely designed to reduce drag .The semi-circle design with bottom sidebags enables the system to remain within the air stream of the bike. Adjustable volume via compression straps further minimizes drag as the luggage is never larger than it needs to be.***
- ***Shoulder straps for off bike use.***
- ***Reflective webbing adds conspicuity at night.***
- ***Heavy-duty zippers offer oversized pulls for easier manipulation with gloves***
- ***85 to 100 liters of storage volume***
- ***Two small, detachable outer bags.***
- ***Solid hold, due to four point fitting.***
- ***Add-on Bags-Connection tentbag (sold separately) offers storage for a tent roll of up to 57cm long x 20cm diameter***

Standard accessories: three-part luggage set, 4 fitting straps, 2 compression belts, carrying strap, 2 support straps for license plate mounting points, paint protection film.

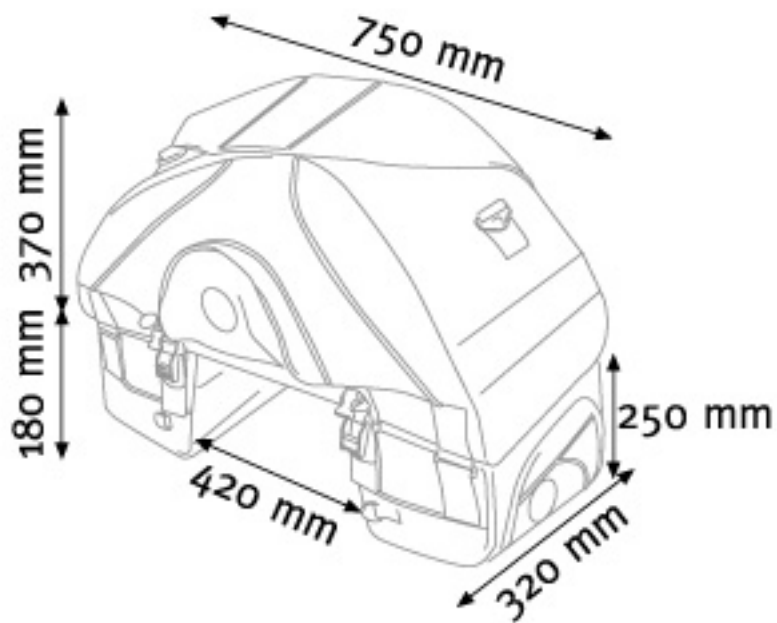

Fits bikes with a tail-section width of up to approximately 42 centimeters.

Bags-Connection has tested its products on most current-model motorcycles. Based on these fitting tests, Bags-Connection recommends the Speedpack Wide for use with the unmodified stock bikes listed below (product may also fit additional motorcycle models):

Aprilia

*RSV1000R Mille & RSV1000R Factory, 2004-
SL1000 Falco
Tuono 1000R
ETV1000 Caponord*

BMW

*F650 Funduro and F650/ST, -'99
F650GS, '00-
F650GS/Dakar, '00-
R1200RT
R850R
R1150R
K1200GT
K1200R
R1150GS Adventure
R1200GS*

** The Speedpack Wide's side pockets prevent access to the F650GS & F650GS/Dakar's fuel*

filler cap. To access the fuel tank, the Speedpack wide must be removed from the bike.

Cagiva

Gran Canyon 900

Ducati

Supersport SS1000DS

Monster 620 / 1000

Harley

XL 883 Sportster 2004

XL 883C Sportster Custom

FXD Dyna Super Glide 2004

FXDX Dyna Super Glide Sport 2004

FXDL Dyna Low Rider 2004

FXDWG Dyna Wide Glide 2004

V-Rod 2004

Honda

CBF500 / CBF600

599 (a.k.a CB600 Hornet)

CBR1000RR

VFR800 VTEC (2002-2005)

ST1300 Pan-European

XL125V Varadero

XL650V Transalp

Kawasaki

KLR650

ZX6R (636cc)

ZX6RR (599cc)

ZX10R

Z750S

ZZR600

ZZR1200

ZX-14 Ninja (a.k.a. ZZR1400)

Moto Guzzi

California EV

Nevada 750 Classic IE

Suzuki

GSX-R 1000, '05-

DL650 V-Strom

DL1000 V-Strom

Triumph

Daytona 650

Daytona 955i

Yamaha
FJR1300
FZ1 (FZS1000 Fazer)
FZ6
TDM900
YZF-R1

